

IMPORTANT NOTICE

This document **MUST** be forwarded to your architect or building contractor to ensure that the site is prepared correctly as any mistakes could be extremely costly.



Pre installation document

Avero



General Site Requirements.

The wall decoration and floor covering must be complete and finished.

Positioning and fixing the unit.

The Avero Bath is freestanding on the floor.

Adjacent walls need to be plumb, flat and clear of obstructions up to 1130mm above the floor. Skirting boards may be left in place.

Fig 1

If the Avero is to be installed in an alcove or into a corner the side wall/walls will also have to be clear for a height of 1130mm.

The bath can be fitted as a Corner unit, Peninsular (P) unit or an Island unit.

A minimum clearance of 150mm (WG) is required at the tap end of the bath to allow for the connection of the services.

A 40mm clearance is required against any adjacent walls (LWG) and fixed appliances (FG) including toilets, radiators, sinks and shower units.

Note: If the bath(corner fitting) is ordered with neatfold stretcher, the gap at the long side of the bath (LWG) would have to be 65mm.

If a Peninsular or Island layout is required with a neatfold stretcher there must be enough clearance for the stretcher to swing and fold to the side of the bath, 400mm minimum.

Fig 1

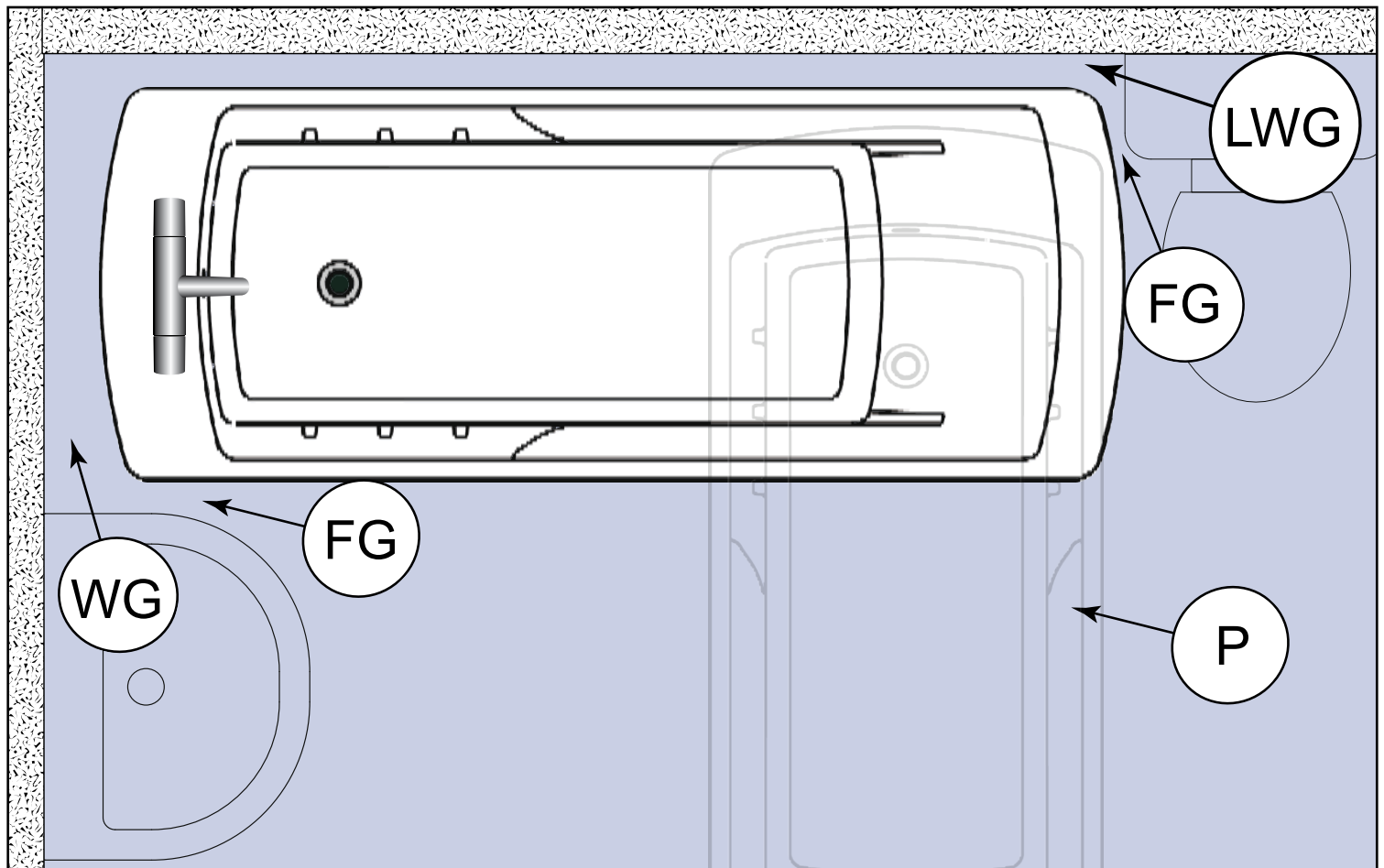

Positioning and fixing the unit - Continued

Fig 2
When calculating the footprint of the bath use the diagram below and ensure the clearances are provided at the ends and at the sides.

The floor area underneath the bath must be kept clear of any obstructions.

The floor must be strong enough (especially in the foot areas) to carry the weight of the bath when full and occupied.

Fig 2

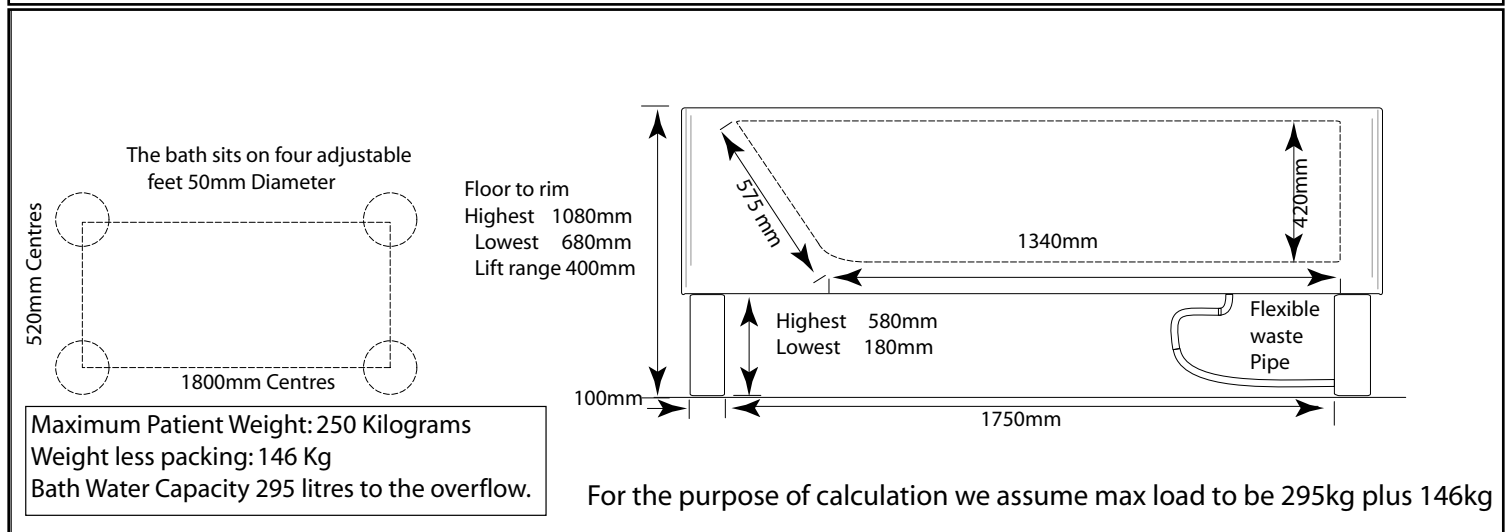
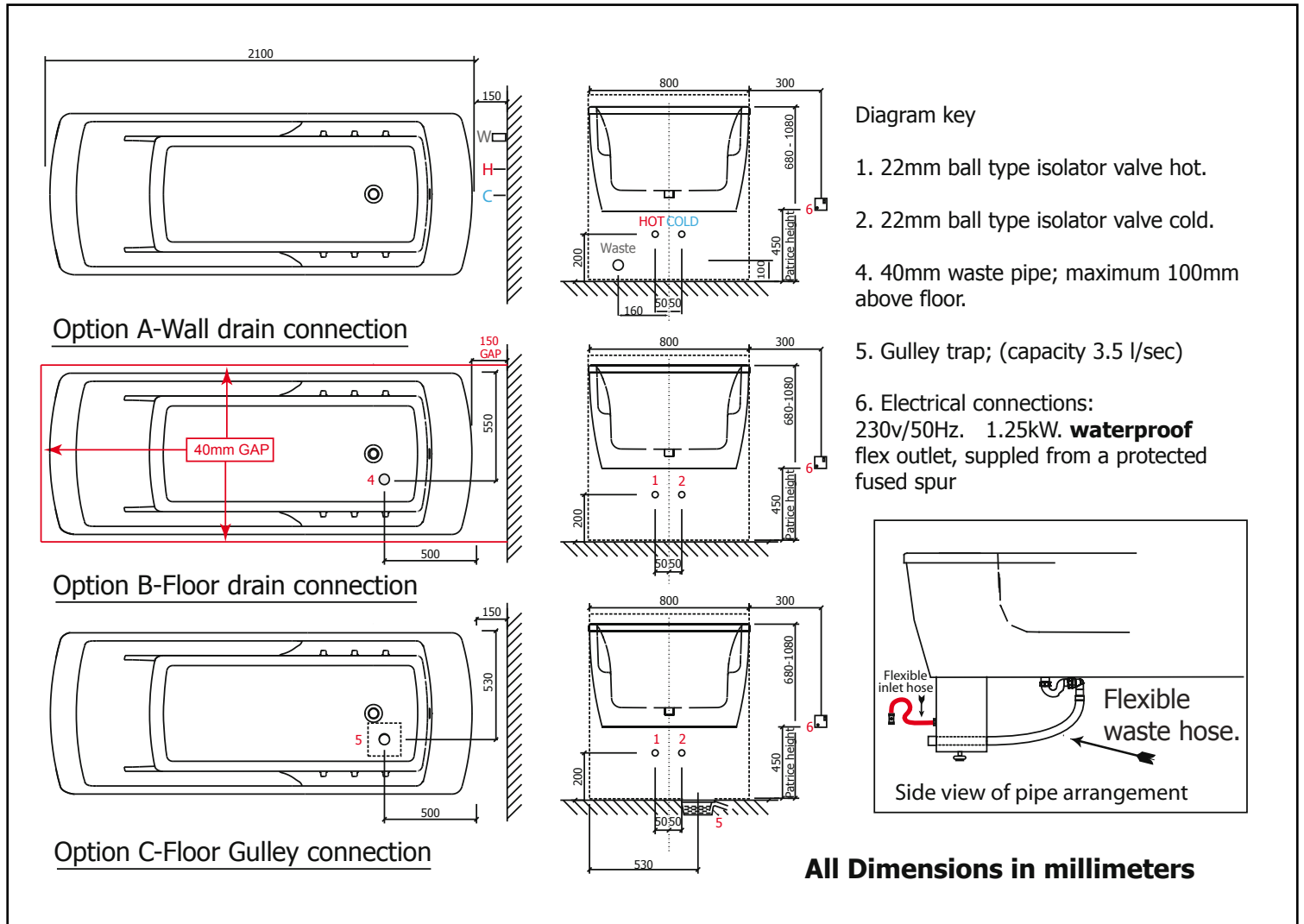

Plumbing Options

Fig 3
 The plumbing options and the outlet positions of the water and waste services must be at the tap end of the bath.
 22mm ball type isolation valves (V) should be positioned and orientated exactly as shown but can be fed through the wall, floor or along the wall from either side. See Fig 5.

Fig 3

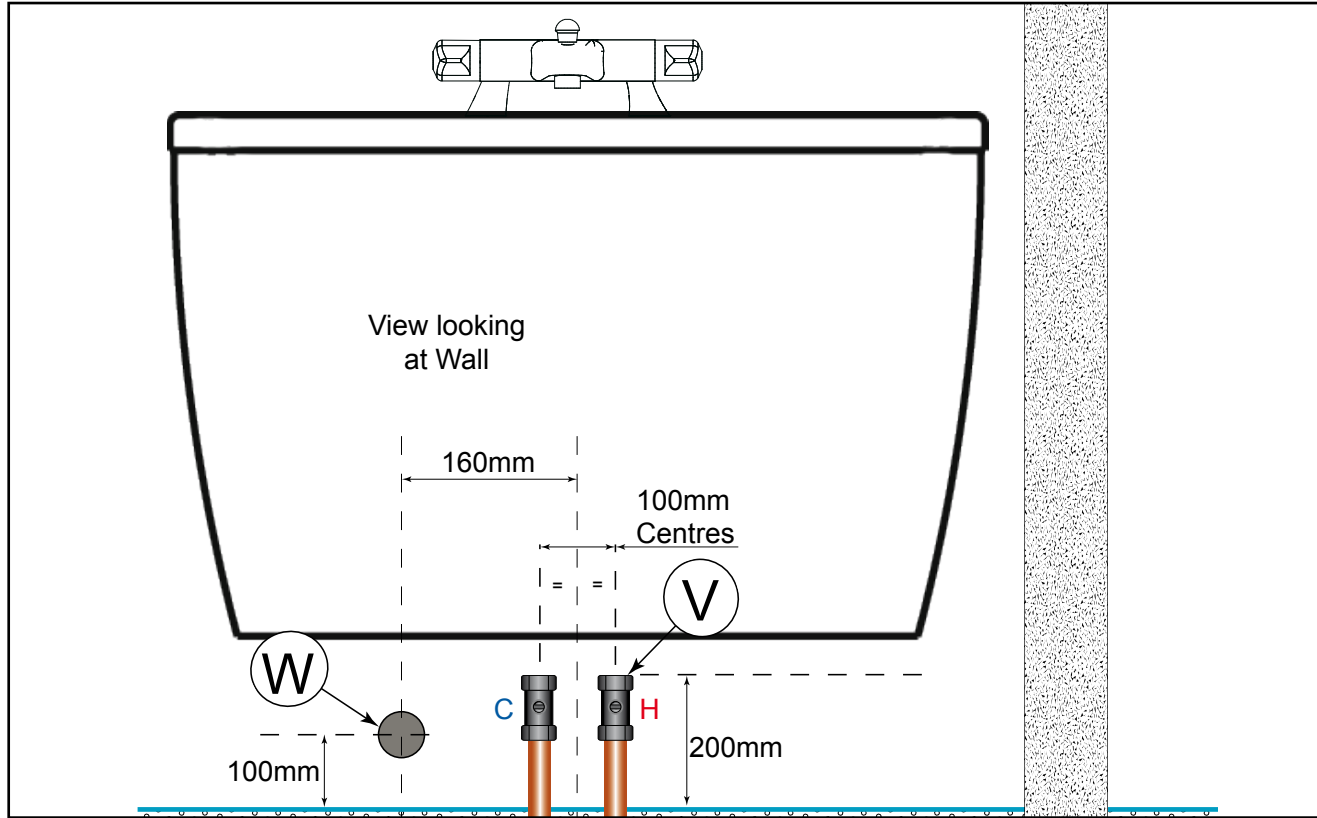
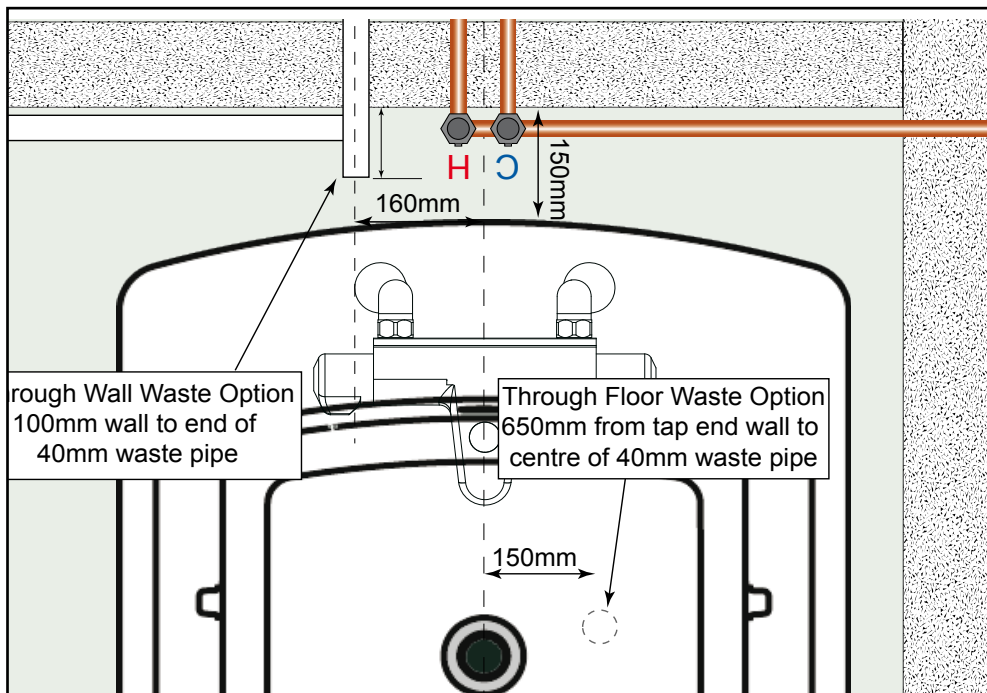

Fig 4
 A 40mm waste pipe (W) is required and should be positioned and orientated exactly in one of the positions in Fig 2 but can be fed through the wall, floor or along the wall from either side.

Fig 4



Plumbing Options Continued.

Fig 5 and 6

If the water service pipes need to be fitted along the wall from a side wall they need to be kept tight against the wall.

If the waste is to be fed along the wall from a side wall it must be kept tight to the wall and be positioned below the water service pipes.

The 40mm waste pipe can be fed through the wall (WW) or floor (WF) as shown and cut to the lengths indicated.

Fig 5

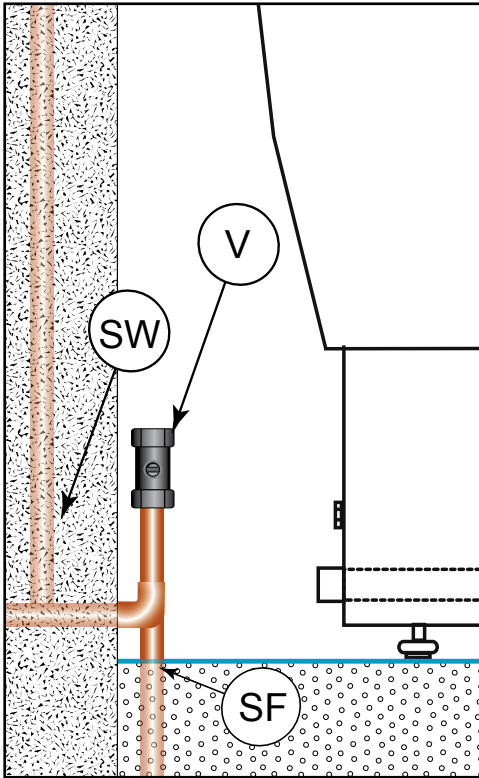
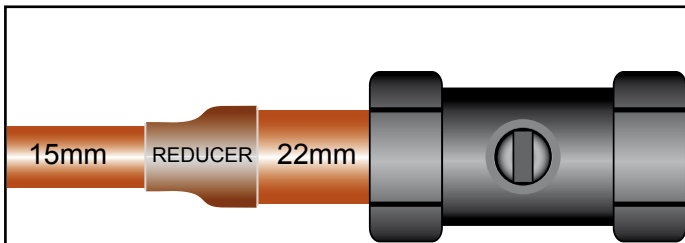
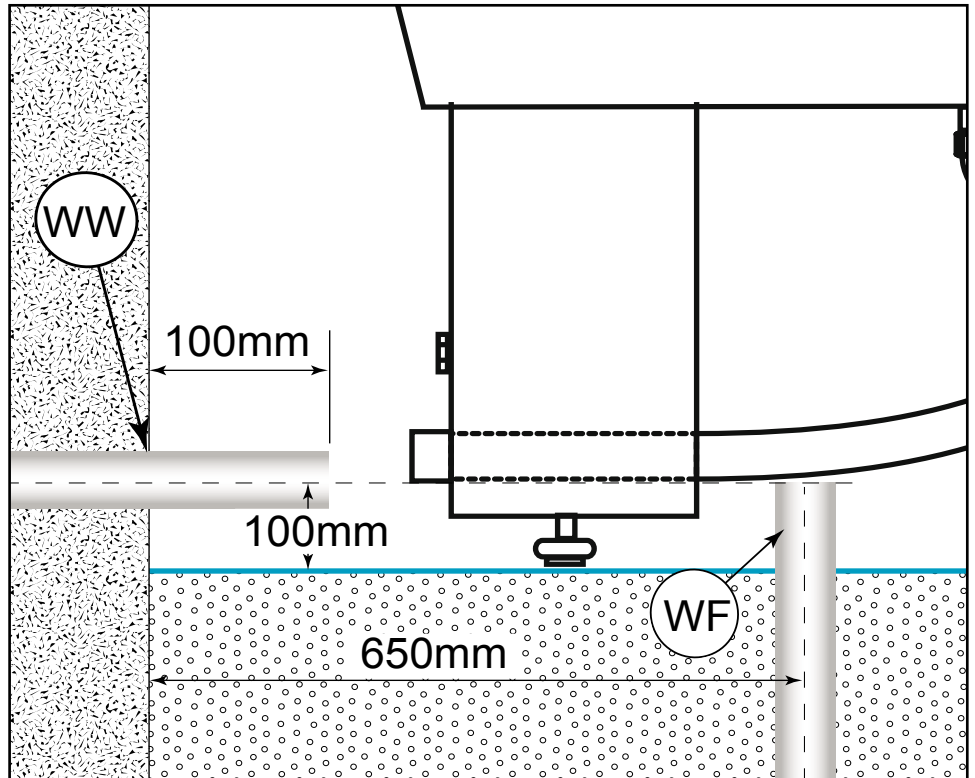

Fig 6



Note: If the site piping is 15mm then this should be expanded to 22mm piping at the valve end to accommodate the valves.

Tap Options

The Avero can be supplied with various tap/mixer sets.

The minimum water pressure on each supply must be 1 bar and a maximum of 10 bar with a differential of no more than 5 bar. Equal Pressures are recommended.

Electrical Connection.

Fig 7 & 8

The bath requires a 1 off 230 volt, 1.25Kw waterproof flex outlet, located at the position shown and supplied from a protected fused spur. The outlet can be on either side of the bath.

Fig 7

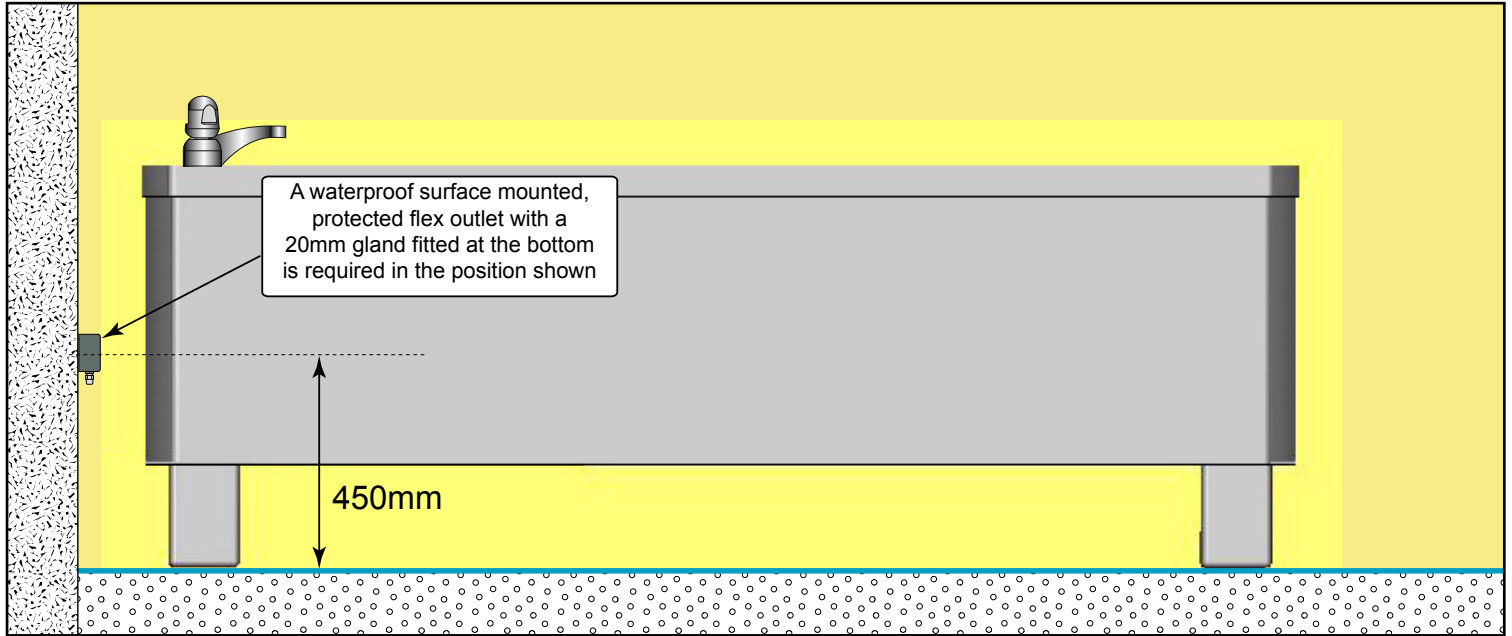
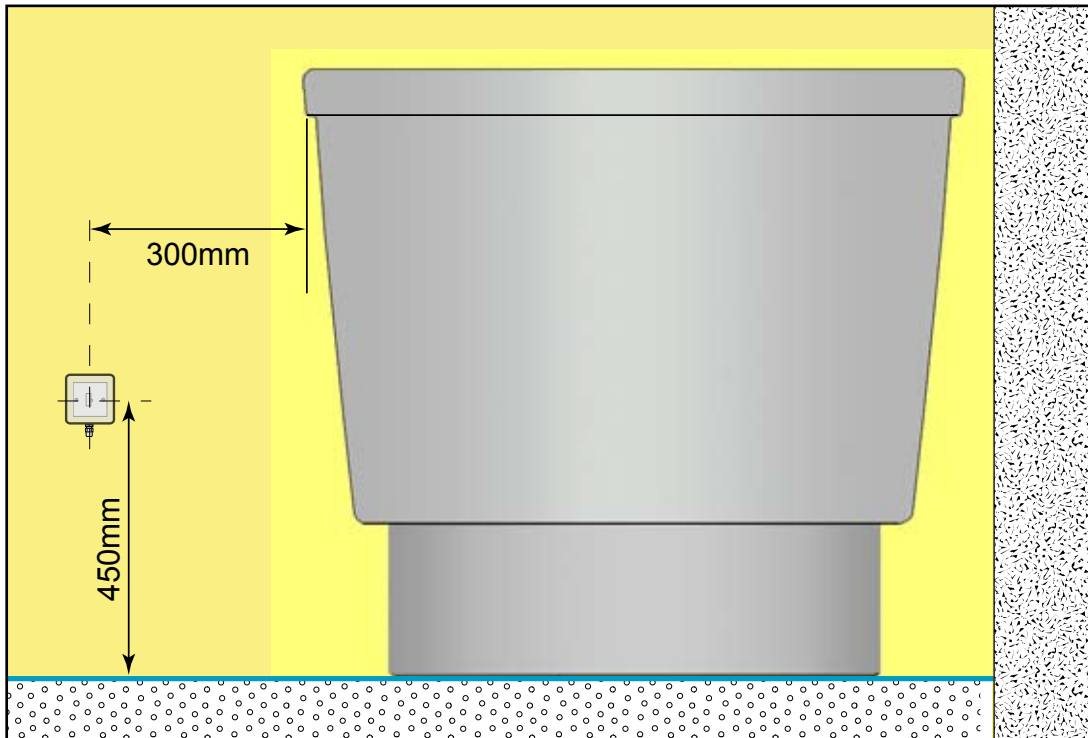

Fig 8



Technical Information.

Electrics

A.C. Input 220 - 240V~, 50/60Hz, 1.25Kw.

DC Output, 24v, 8 Amps.

Ingress protection IP 65

Maximum Patient Weight

250 Kilograms

Weight less packing

146 Kg

Length

2100mm.

Width

800mm

Height Range

680mm Minimum

1080mm Maximum.

Bath Water Capacity

295 litres to the overflow.

Water Pressures

A Minimum of 1 bar is required on both Hot and Cold water supplies.

Maximum 10 bar.

Hot and cold pressures should be equal where possible.



Unit 11f, Coln Park

Andoversford

Gloucestershire

GL54 4HJ

Tel 01242-820820 Fax01242-821110

e mail: sales@astorbannerman.co.uk

VAT Reg No. 630609068